

CAPOT EN KIT POUR IMPRIMANTE 3D UM S5

INSTRUCTIONS D'ASSEMBLAGE

Lien de téléchargement de la version pdf : www.accante.com/files/Ultimaker/ums5

Aucune responsabilité ne pourra incomber à Accante : en cas de dommages accidentels ou indirects en relation avec le produit et en cas de modifications des performances liées à ce kit.

OUTILLAGE NECESSAIRE

Tournevis

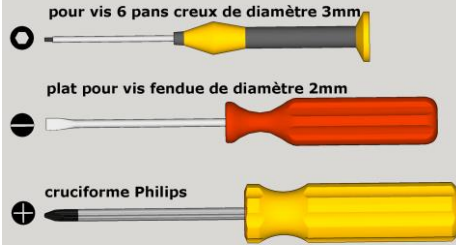

CONTENU DU PACKAGE

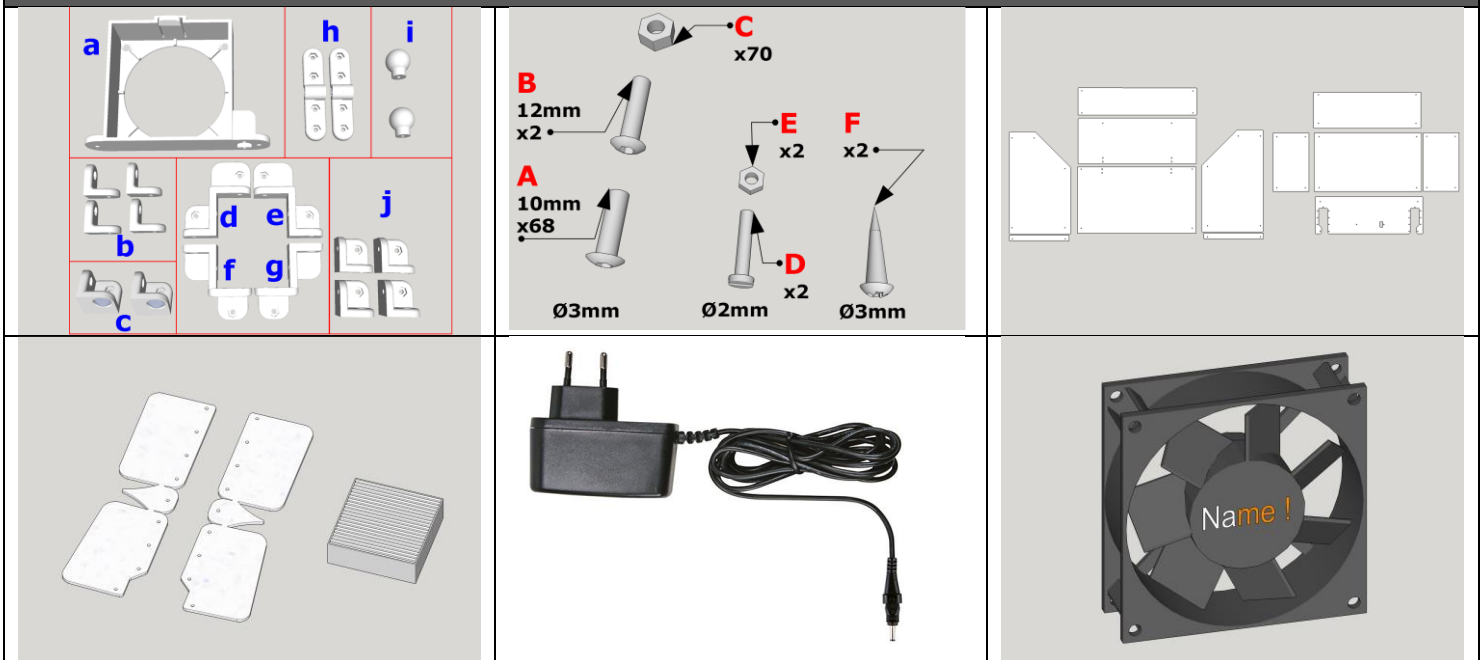

MONTAGE 1^{ère} partie

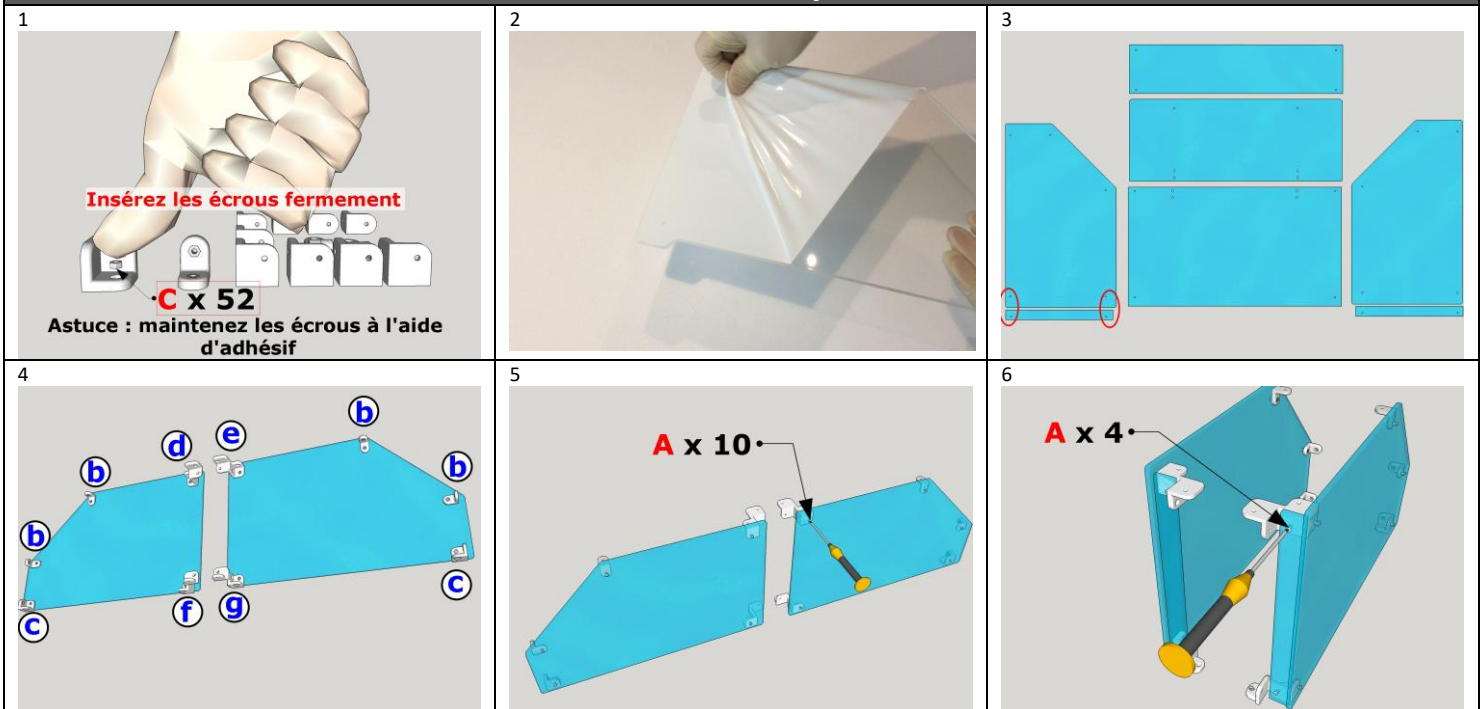

7

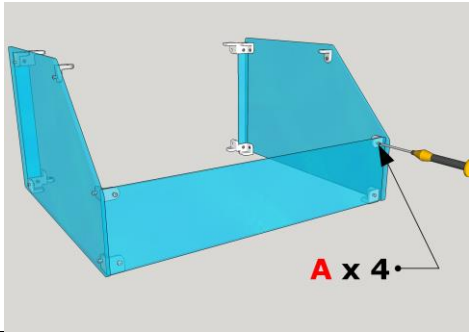

8

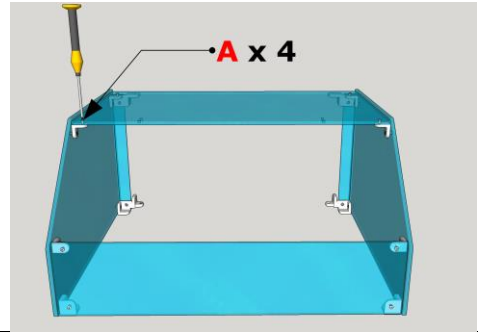

MONTAGE 2^{ème} PARTIE

9

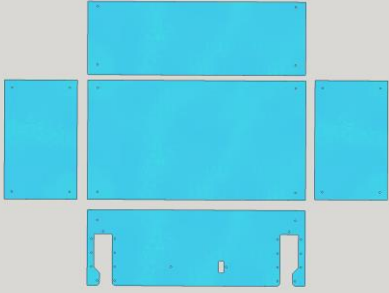

10

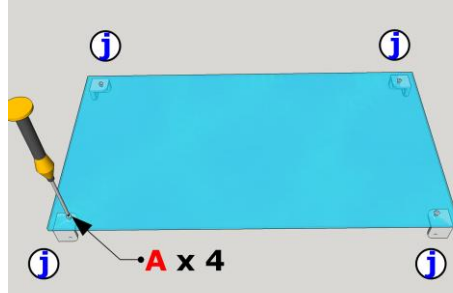

11

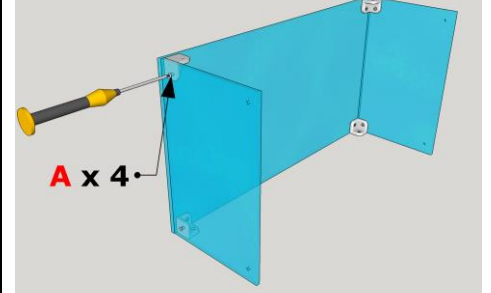

12

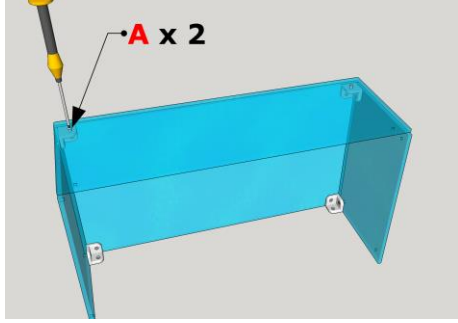

13

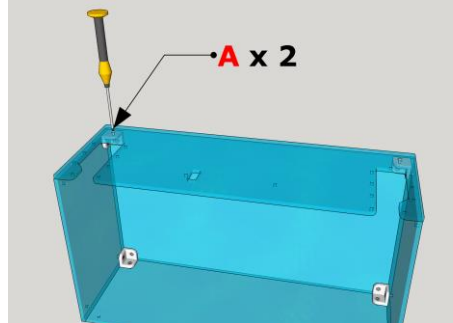

14

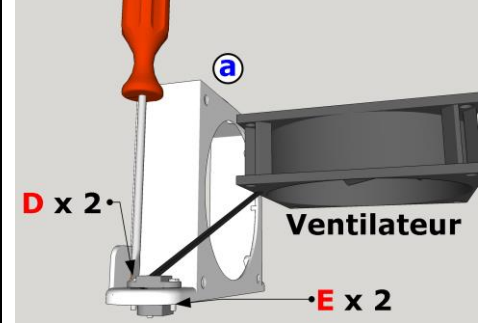

15

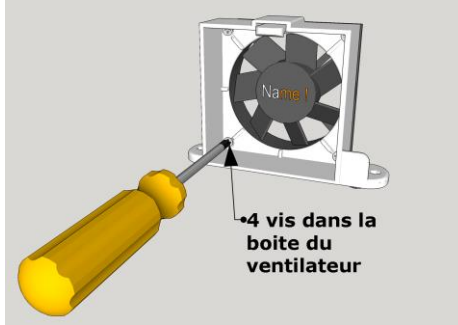

16

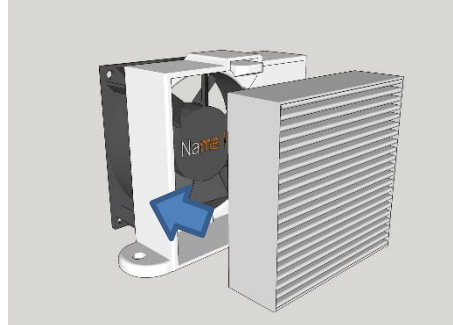

17

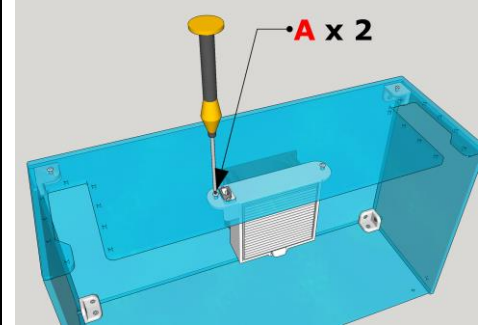

18

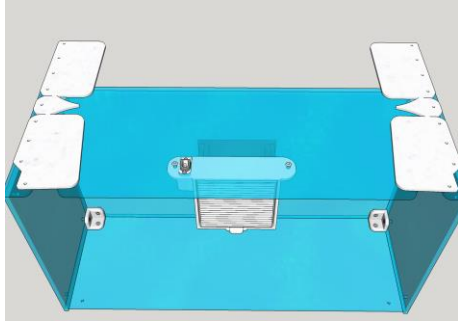

19

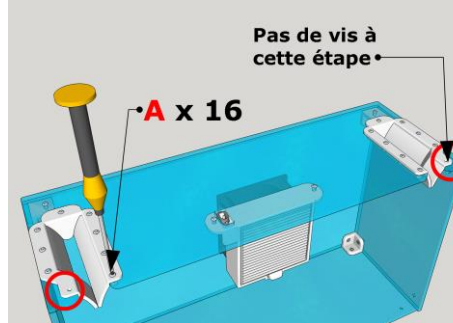

20

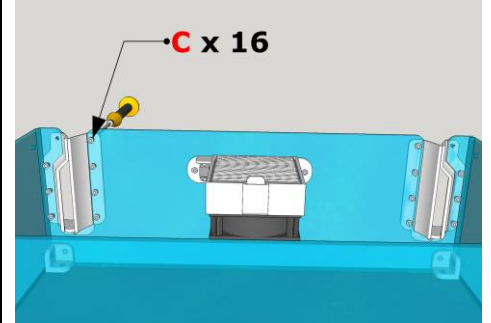

ASSEMBLAGE DES DEUX PARTIES

21

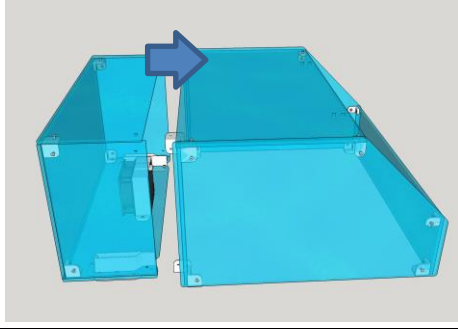

22

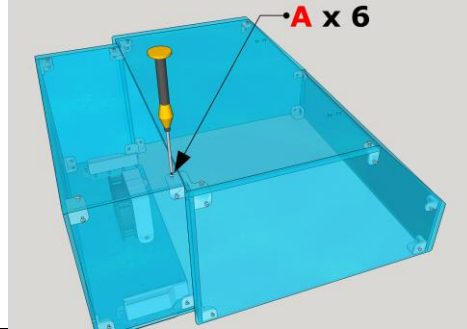

23

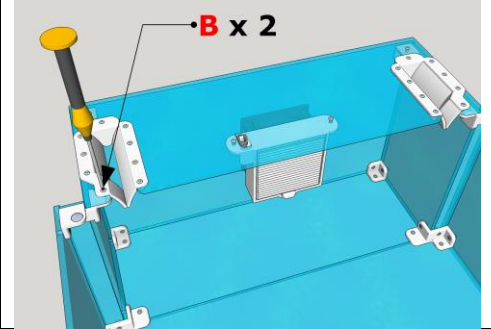

MONTAGE ET AJUSTEMENT DE LA TRAPPE

24

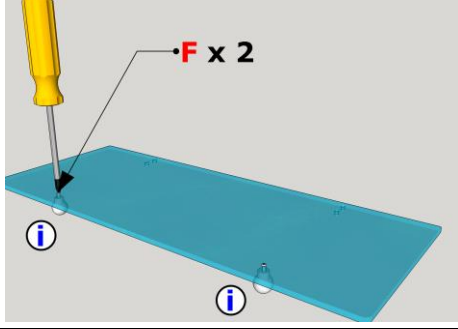

25

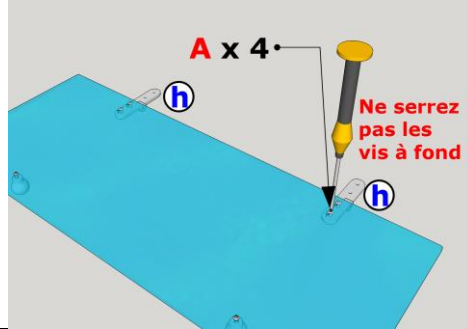

26

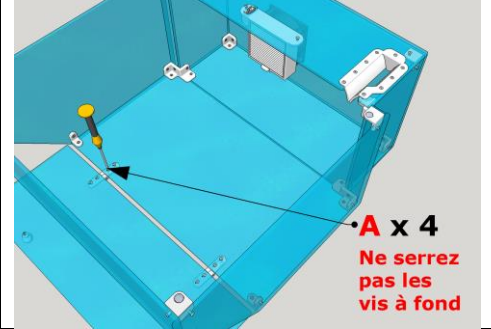

27

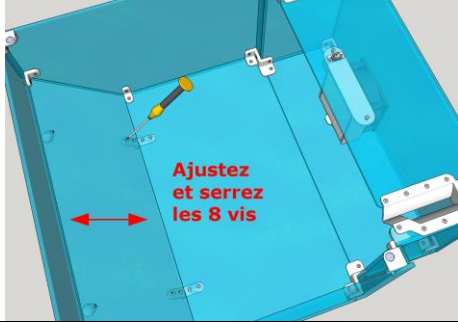

POSE SUR IMPRIMANTE 3D

28

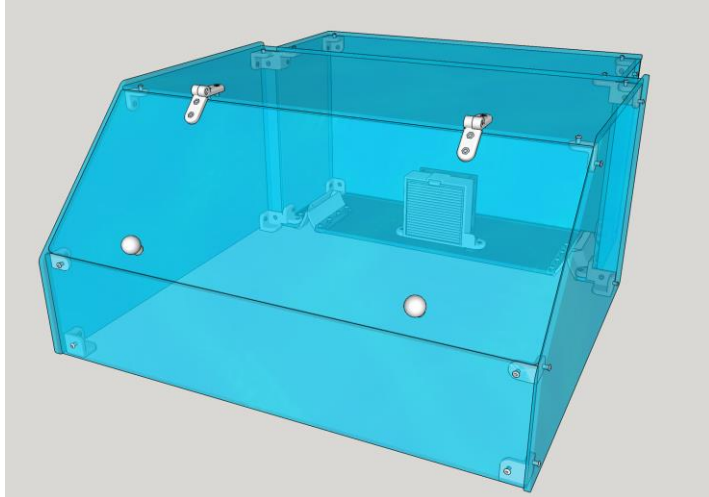

29

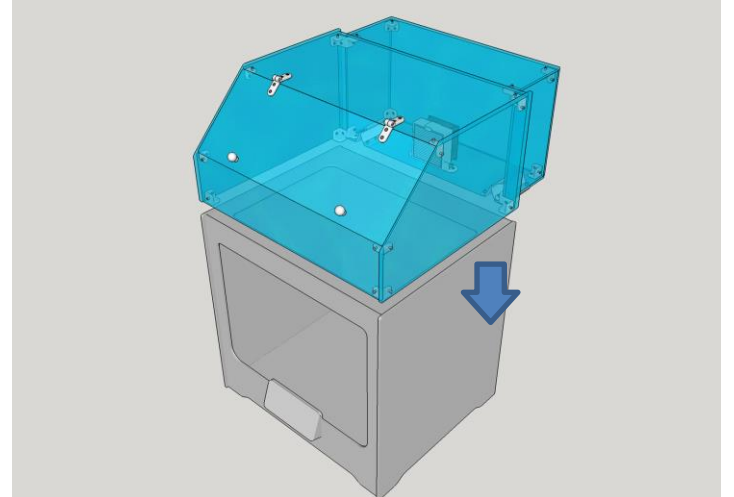

Vérifiez le serrage des vis après quelques heures.

Modèle déposé par Accante® - Reproduction interdite - Fabriqué en France